

RD350F



YAMAHA RD350F—TESTED ON THE TRACK, TOP ON THE STREET!





Without any doubt, the Yamaha RD350F is the world's most popular machine in production-class road racing.

Literally thousands of them have competed all over the globe, at every level from international to local events.

Not only that, the RD350F is as successful as it is popular!

No bikes win more production machine races than the Yamaha RD350F — a proud boast that is enhanced by the fact that *two* World Formula Two Championships in the past five years have been won with machines using the RD350 road-going engine as the basis for a racer!

With the RD350F, in fact, Yamaha were able to create a whole new class of racing. Across the world, from Europe to America and Australia, hundreds of young riders battle each season on identical Yamaha twins in RD Cup events. Wherever it is staged, the RD Cup has provided some of the closest, most exciting racing ever seen... regardless of class. It has been responsible for launching a lot of young talent on to promising Grand Prix careers.

Not surprisingly, the bike which has been the automatic choice of thousands of production-class racers over the years is a superb, high-performance road machine. Its strong racing heritage means that the RD350F is as safe as it is stimulating, with handling and braking being right up to the standards demanded by the engine performance

For over two decades, the development of our two-stroke sports machines has been directly linked to our road racing activities. The equipment used on today's Yamaha Grand Prix road racers is actually being tested for the RD range of tomorrow!

Yamaha's Monocross rear suspension was developed for our World Championship-winning road racers, as were the wide-cradle, fully triangulated chassis, the triple disc

brakes and the variable-rebound damping front forks.

Our liquid-cooling system; the YPVS exhaust power valve which revolutionised two-stroke engineering; reed valve induction... All of these, and more, were first tested and proved on the Grand Prix race-tracks before being built into your Yamaha RD350F.

There's no better development programme that we can think of! Can you?

The engine of the Yamaha RD350F is almost unique amongst road machine power units in that it is a World Championship winner in its own right. The 1985 World Formula Two Championship was captured by a tuned version of our deservedly famous, twin-cylinder two-stroke... the second time that an RD motor has taken this road racing title in the past five years!

Actually, this isn't as surprising as it might seem, for our RD models have

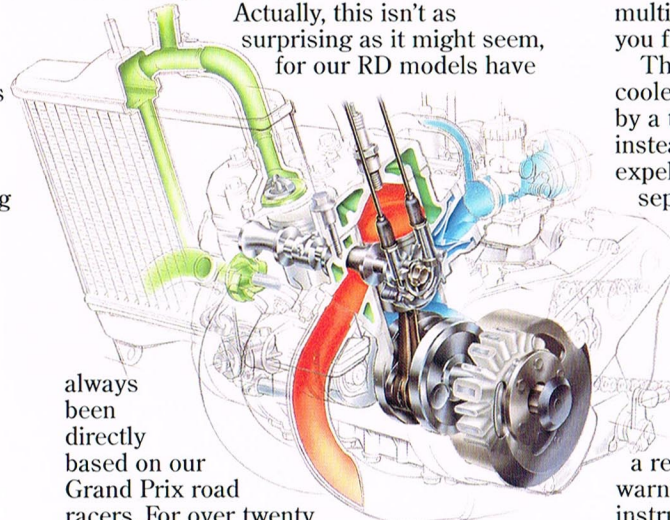

always been directly based on our Grand Prix road racers. For over twenty years, the technology that we have proved with World Championship success has always been quickly applied to our road machines. That's why the Yamaha RD twins are currently the most successful and popular choice for production class racers around the world... and why we've been market leaders in the middleweight supersports category for a generation.

Another, even more significant, result of this continuing close link between our racing and road machines is that *every* important advance in two-stroke engineering has been

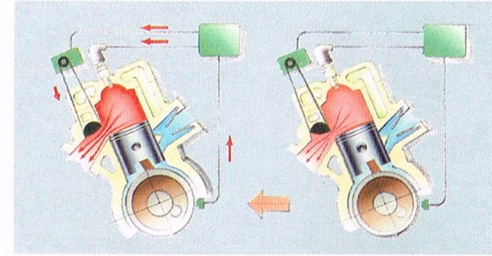

introduced to the road rider by the Yamaha RD range!

Liquid cooling; automatic lubrication; pre-set electronic ignition with built-in advance/retard capability; reed valve Torque Induction; variable exhaust timing (YPVS); multiple cylinder porting... all brought to you first by Yamaha.

The current RD350F engine is liquid-cooled, with coolant temperature controlled by a thermostat. The system is "sealed" and, instead of heat-expanded coolant being expelled out of an overflow, it is directed to a separate header tank, where it remains until it cools off and its volume diminishes. This type of system needs virtually no topping up under normal running conditions.

Lubrication is automatic, with oil contained in a separate tank and pump-fed under pressure to the crankshaft bearings and other friction-stressed surfaces. As the system is not a re-circulating one, a warning light on the instrument panel keeps the rider informed of the oil level.

On the induction side of the engine, reed valves control the mixture flow. These respond to the internal engine pressure changes, opening to

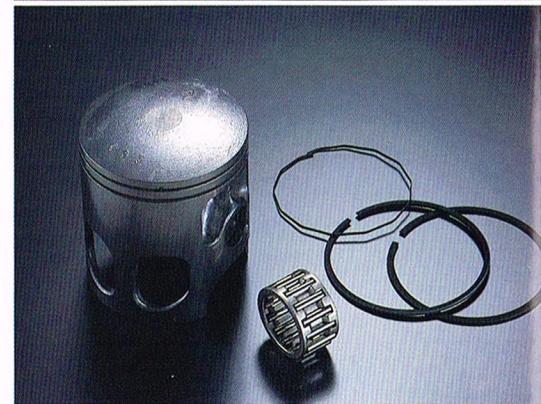
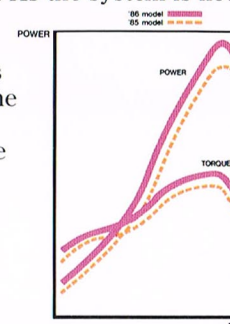

admit the fuel/air charge when the pressure is low and closing off the intake flow when crankcase pressure is high. Thus the engine gets exactly the amount of fuel it needs and no more. Power-wasting turbulence in the inlet tract and messy carburettor blowback are eliminated and there is instant pick-up from the lowest rpm.

Port areas and timing have been revised to give a horsepower and torque boost for 1986.

Piston crowns have been made stronger and their skirts lengthened to prevent the pistons "swinging" in the bores. Both durability and efficiency are improved. New, carbon-steel expander material in the lower piston rings also keep the pistons running true in the bores as they exert more pressure on the cylinder walls. Both rings are now of a special cast-iron material which prevents them from sticking in their grooves and both cylinder bores and bearing surfaces are treated with an anti-friction process.

New expansion chamber exhausts, with separate racing-type silencers, also boost the power, while the clutch assembly is strengthened to cope with the increased output.

Finally, one of the most significant single advances in two-stroke design was the

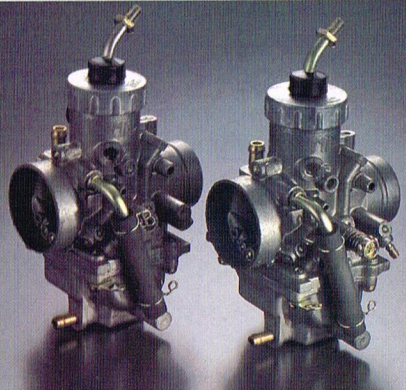

variable exhaust timing capability introduced by the Yamaha Power Valve System. YPVS utilises a cylindrical barrel valve rotating transversely across the exhaust port. This valve has a graduated cutaway in it which, at its maximum depth, matches the wide-open area of the exhaust port. The valve's action is linked to engine speed, so that it permits maximum port opening at maximum rpm. At lower engine speeds, the diminishing cutaway gradually closes down the port and so retards its opening.

This allows the RD350F to develop maximum horsepower in conjunction with the widest-possible spread of torque. With one single component, Yamaha eliminated what was previously the biggest problem with high-performance two-strokes. Prior to the advent of YPVS, low-end pulling power had to be sacrificed to gain extra top-end speed. Not any longer, thanks to

Yamaha's exhaust power valve!

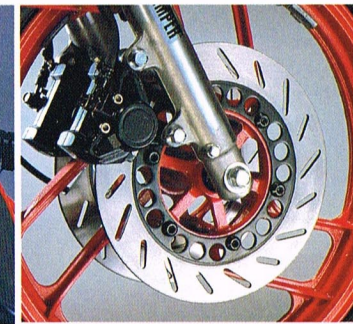
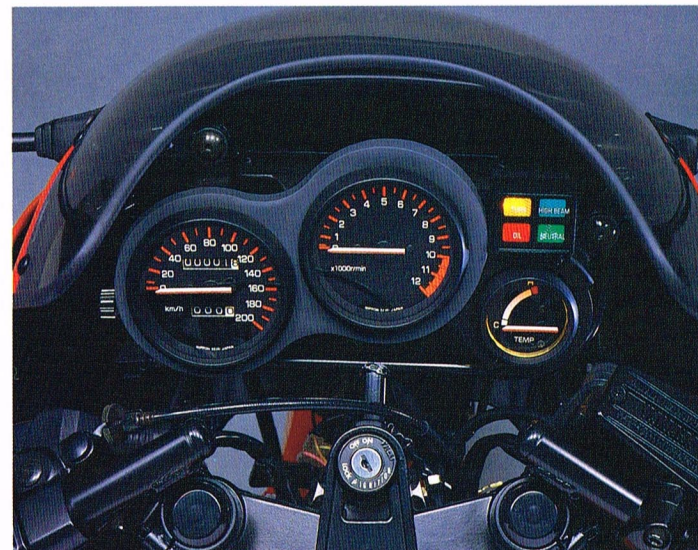
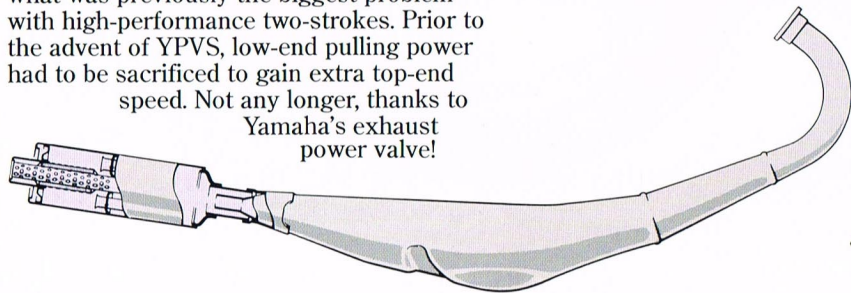

Yamaha introduced the modern concept of single shock absorber rear suspension to the world over ten years ago and have since continually refined their Monocross system to maintain the advantage that it established.

Now Monocross features a De Carbon-type shock, mounted low down behind the engine unit, where its effect on front-to-rear weight balance is virtually neutralised. The pre-load adjustable shock controls a box-section, high-tensile steel swinging arm that exerts leverage in rising rate proportional to wheel movement. The bigger the bumps, the more the resistance.

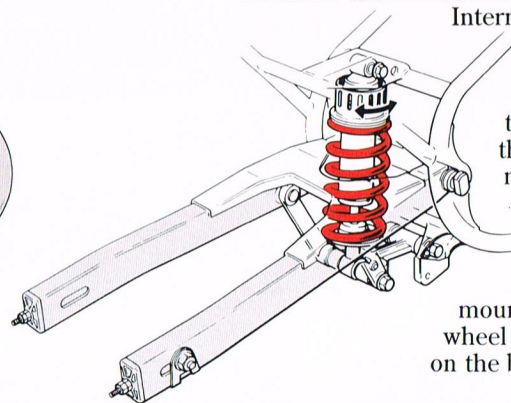

Internal chain adjusters within the swinging arm tube ends mean that the inherent torsional strength of the box-section is maintained throughout the unit. Thus maximum strength is retained around the rear axle mounting to keep the rear wheel tracking in line even on the bumpiest of surfaces.

At the front end, the forks have automatically-variable rebound damping that stiffens fork action as travel increases. They are braced against lateral deflections by an alloy fork bridge. This blends neatly with the new aerodynamic front fender that directs airflow smoothly through a notorious turbulence zone.

The instrument console is racing-styled... with the emphasis on the centrally mounted tachometer. The console is mounted within the frame-fitted fairing, so that its weight has no effect on the front forks' steering response. New handlebars are lower and flatter, to put the rider down behind the fairing screen when tucked-in, with the easy-to-operate control switches within reach of the rider's thumb while holding the handlebar grips.

Foot controls are also new for 1986 — neat, lightweight footrest brackets that also carry positive-action gearchange and rear brake linkages.

Major re-styling of tank and bodywork plus quality refinement of some mechanical parts. And finally tank and bodywork have received a distinctive re-style to keep the RD right in the fashion spotlight!

The sleek, aerodynamically effective fairing is the focal point of the Yamaha RD350F. It provides both rider protection and a performance gain.

This year's handlebars are lower and flatter, keeping the rider low and tucked-in behind the wind-cheating fairing.

Seat height is lower and the seat pad is individually sculptured to give positive location for both rider and passenger.

New-look tank is deeper and more slab-sided, following our GP road racer styling. Smooth profile is maintained by use of flush-fitting, aircraft-type filler cap.

Re-styled side covers blend smoothly into the neat new tail cowling and rear light cluster.

Low-pressure, high-density casting process reduces wheel weight. Its increased strength also permits yet more weight saving by allowing new "triple twin-spoke" design.

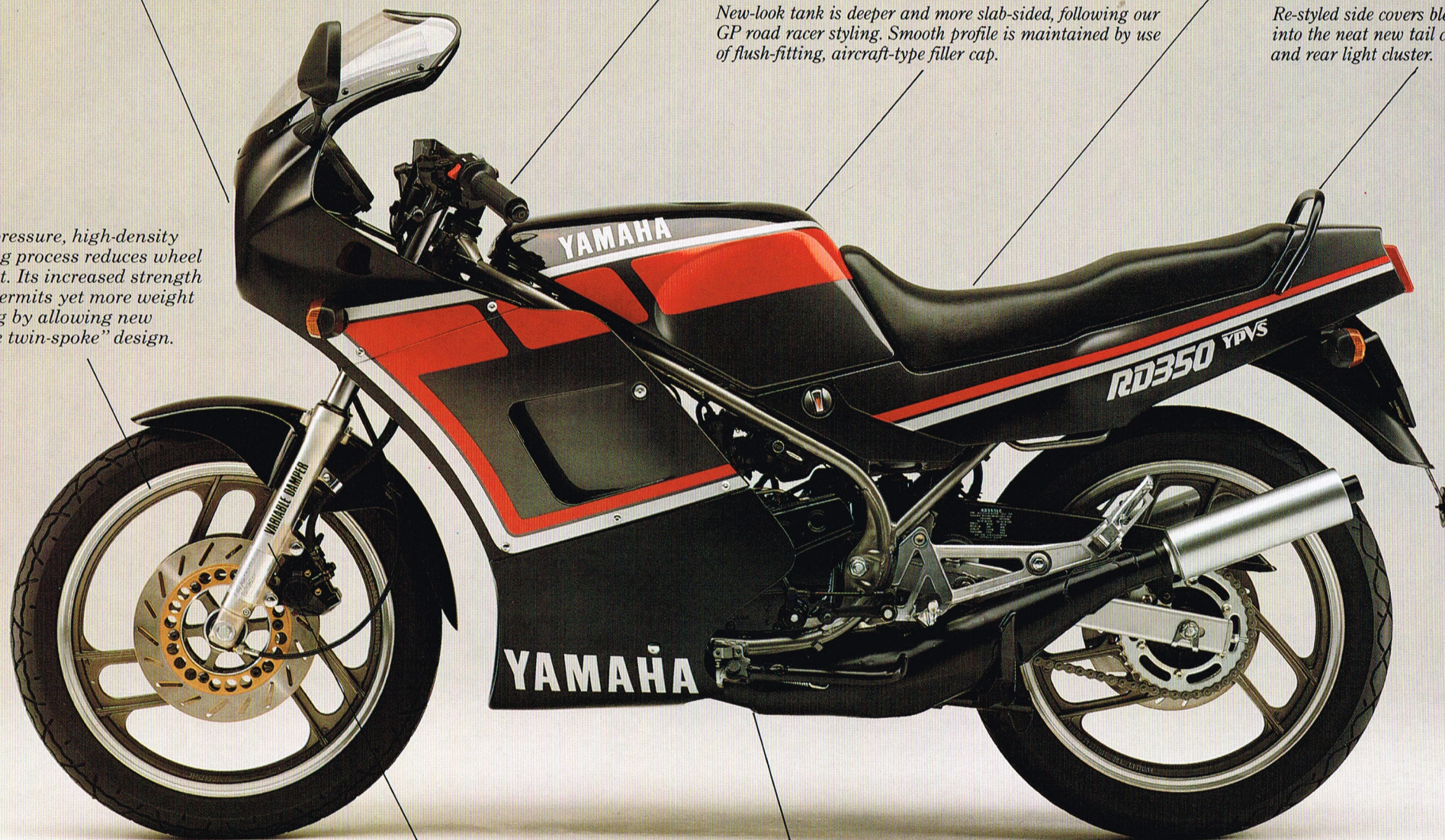

Front forks have self-adjusting, variable rebound damping which minimises front end lift when accelerating hard out of corners. Air-assisted springing aids smooth shock absorption.

Expansion chamber exhaust pipes are part of the package that increased RD350F performance this year. They are fitted with separate, racing-type silencer canisters that restrict noise without affecting power output.



RD350F SPECIFICATIONS

ENGINE

Type..... 2-stroke, liquid-cooled,
Torque Induction, twin
Displacement..... 347 cc
Bore and stroke..... 64.0 × 54.0 mm
Compression ratio 6.0:1
Max. power (DIN)..... 63.0 PS
(46.3 kW) @9,000 rpm
Max. torque (DIN) 5.0 kg-m
(49.1 Nm) @9,000 rpm
Lubrication Autolube
Carburation..... Mikuni VM26 (2)
Ignition CDI
Starter system Kick
Fuel tank capacity 17.0 lit.
Oil tank capacity 1.6 lit.
Transmission..... 6-speed
Final transmission Chain drive

CHASSIS

Overall length 2,095 mm
Overall width 700 mm
Overall height..... 1,190 mm
Seat height..... 790 mm
Wheelbase 1,385 mm
Min. ground clearance 165 mm
Dry weight..... 141 kg
Suspension

Front Telescopic forks
Rear..... Monocross

Brakes

Front Hydraulic double disc
Rear..... Hydraulic disc

Tyres

Front 90/90-18 51H
Rear..... 100/80-18 58H

Specifications and appearance of Yamaha motorcycles shown here may vary according to requirements and conditions and are subject to change without notice.

For further details, please consult your Yamaha dealer. Always wear a helmet and eye protection.

Mitsui Machinery Sales (U.K.) Ltd.
Oakcroft Road
CHESSINGTON/SURREY KT9 1SA
Tel: 01-3975111
Tlx: 929929

 **YAMAHA**
MC-RD350F-88E