

YAMAHA

XTZ750 SUPER TÉNÉRÉ





Yamaha XTZ750 Super Ténéré. Another world could be just a tankfull of fuel away!

There was a time when only the privileged few could explore new worlds in their quest for adventure. But not any more.

So if you're the kind of person who wants to visit faraway places and seek out new experiences, we have exactly the right machine for you. The Yamaha XTZ750 Super Ténéré.

Just take one look at this unique bike and you'll realise that it is like no other motorcycle. To begin with, the Super Ténéré is powered by a very special engine. With advanced 5-valve heads, the parallel-twin design pumps out massive torque as well as strong top-end power. Centre of gravity is kept low by inclining the block forwards, and smooth running is assured with a gear-driven counterbalancer.

Chassis design is straight from our desert racers, with a high-tensile steel frame offering immense strength combined with low weight. And to handle all kinds of hostile terrain the XTZ750 features massive 43 mm front forks and our competition-proven Monocross rear end.

With a long-range fuel tank and aerodynamic fatigue-reducing head fairing, the Yamaha Super Ténéré is equipped to take you into a whole new world.

Just add fuel.

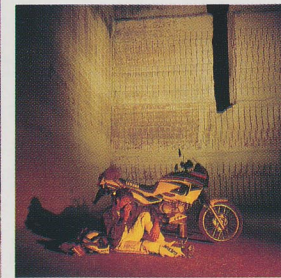
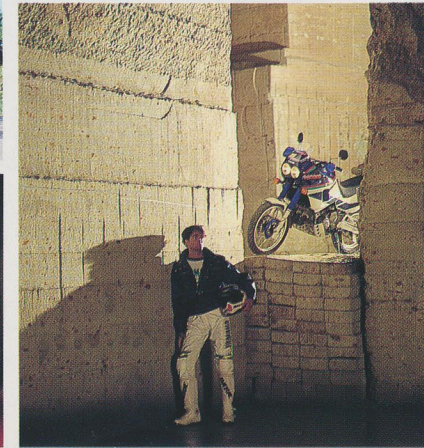



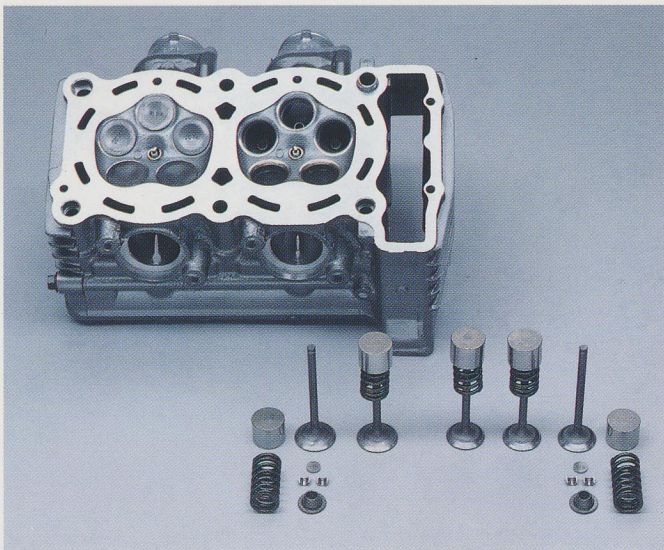

Engine

With high-efficiency 5-valve heads, twin downdraught carburetors and gear-driven balancer mechanism, the XTZ's motor is one of the most technologically advanced big twins ever produced and being inclined forwards, the machine's centre of gravity is kept low for excellent handling performance.



Instrument panel

Comprehensive rider information is supplied by the neatly-recessed console. Mounted in the head fairing, the instrument panel includes a speedometer, trip meter, tachometer and water temperature gauge, as well as a range of indicator lamps.



Seat/luggage rack/tie hooks

Deeply-padded dual seat is designed to carry a rider and passenger in comfort between each 26-litre fuel stop. The strong rear rack features tie hooks to give a useful load-carrying capacity, and for passenger convenience integral grab handles are featured.



Fairing/headlamp

Aerodynamically-efficient head fairing is developed from our desert race machinery and significantly reduces rider fatigue on long-distance journeys. The tank-mounted assembly incorporates Fresh Air Intake (FAI) ducts for optimum cylinder filling, and houses powerful twin headlights for excellent night-time visibility.



Front forks/front brake

Large diameter 43mm front forks with a full 235 mm of front wheel travel smooth out the roughest terrain and give a luxurious ride on the highway. And for supersports-standard stopping power the XTZ uses twin 235 mm front discs with efficient 2-pot calipers.

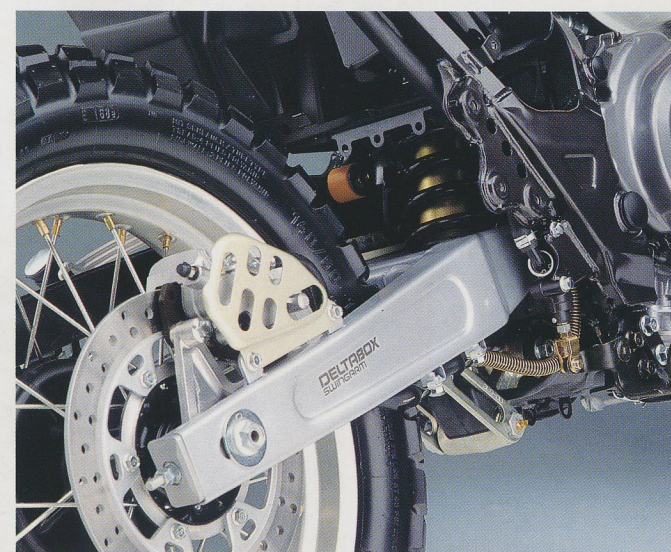

Rear suspension/rear brake

Competition-proven rising-rate Monocross rear suspension system features a strong Deltabox swinging arm and heavy-duty preload-adjustable rear shock offering 215 mm back wheel movement. Rear stopping power is delivered by a single 245 mm rear disc.



SW/R (Silky White/Raspberry Red)



NBB (New Black Blue)



SW/B (Silky White/Dynasty Blue)



Always wear a helmet, eye protection and protective clothing. Yamaha encourages you to ride safely and respect fellow riders and the environment. Specifications and appearance of Yamaha products shown here may vary according to requirements and conditions, and are subject to change without notice. For further details, please consult your Yamaha dealer.

XTZ750 Super Ténéré
TECHNICAL SPECIFICATIONS
ENGINE

Type 4-stroke, liquid-cooled,
DOHC 5-valve,
parallel twin cylinder
Displacement 749 cc
Bore & stroke 87.0 x 63.0 mm
Compression ratio 9.5: 1
Max. power
(DIN) . . . 70 PS (51.5 kW) @7,500 rpm
(ISO) . . 66.5 PS (48.9 kW) @7,500 rpm
Max. torque
(DIN) . . 6.8 kg-m (66.6 Nm) @6,750 rpm
(ISO) . . 6.5 kg-m (63.7 Nm) @6,750 rpm
Lubrication Dry sump
Carburation . . Mikuni BDST38 x 2
Ignition Transistorised (digital)
Starter system Electric
Fuel tank capacity 26.0 litres
Oil tank capacity 4.2 litres
Transmission 5-speed
Final transmission Chain

CHASSIS

Overall length 2,285 mm
Overall width 815 mm
Overall height 1,355 mm
Seat height 865 mm
Wheelbase 1,505 mm
Min. ground clearance . . 240 mm
Dry weight 195 kg
Front suspension . . Telescopic forks
Rear suspension . . . Swinging arm
(Monocross)
Front brake . Dual 245 mm Ø discs
Rear brake . Single 245 mm Ø disc
Front tyre 90/90-21 54H
Rear tyre 140/80-17 69H



Mitsui Machinery Sales (U.K.) Ltd.
Oakcroft Road
CHESSINGTON/SURREY KT9 1SA
Tel.: 081-3975111
Tlx: 929929



LIT-3MG-0107016-91E